

## SAFETY

**WARNING:** This product contains magnets which may affect pacemakers. Failure to follow this warning could result in device malfunction.

**WARNING! CHOKING HAZARD!** Small parts, not for children under 3 years old.

**Notice:** Only use abrasives recommended for this tool in accordance with these instructions.

**WARNING!** To minimize the risk of injury, always use proper eye and respiratory protection. Failure to follow this warning could result in severe injury or death.

## WARRANTY

## 3 YEAR WARRANTY

This sharpener is covered by Work Sharp's 3-year warranty. We stand behind and support our products – contact us if you need assistance, parts, or service.

Warranty for consumer not industrial or commercial use, excludes abrasives. Register your warranty online at [WorkSharpTools.com](http://WorkSharpTools.com).

Work Sharp® is a registered trademark of Darex, LLC

For Patent Info Visit: [worksharptools.com/patents](http://worksharptools.com/patents)

Designed, calibrated and quality checked in Ashland, OR using foreign components.

## QUESTIONS?

[WorkSharpTools.com](http://WorkSharpTools.com) / 1.800.418.1439

PLEASE LEAVE A REVIEW WHERE YOU PURCHASED YOUR PRODUCT



## WORK SHARP

PO Box 730  
210 E. Hersey St.  
Ashland, OR 97520 USA

- ▶ **CLAMPING A KNIFE:** Seat the blade spine into the V-Block Clamp™ with the blade centered in the Clamp Jaws. Align the cutting edge parallel to the clamp jaws if the knife design allows.

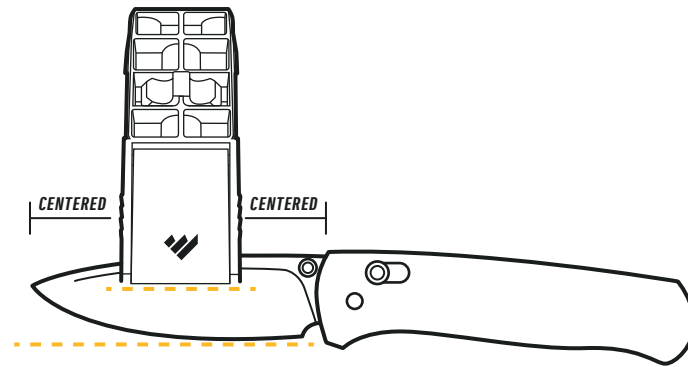

- ▶ **STARTING POSITION:** Note the white alignment mark on the sharpening chassis. Make sure it is pointing up. Insert the V-Block Clamp™ into the sharpening chassis so the knife handle is on the right side. This will make it easier to flip the blade over while sharpening smaller knives.

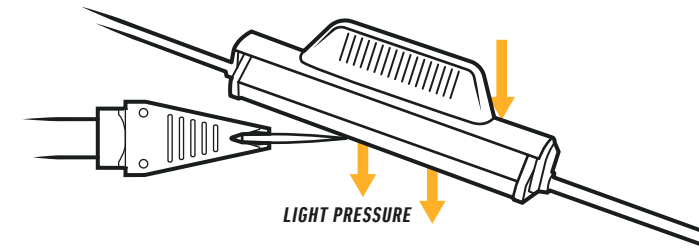
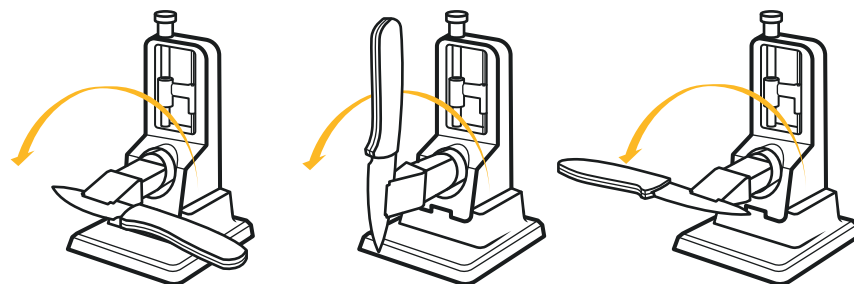
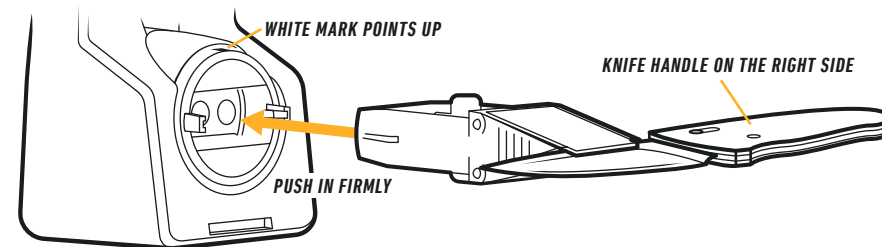

- ▶ Use light pressure when sharpening (weight of the Tri-Brasive®). Let the abrasive do the work and take your time. You'll get a better edge and you will have more fun doing it!
- ▶ First Time Sharpening: Use all three Tri-Brasive® grits to ensure you establish a consistent edge angle along the entire length of the blade and remove any edge damage or irregularities from previous sharpenings.
- ▶ Re-Sharpening: Use only the Ceramic Hone for frequent touch ups, the Fine Diamond may be required to restore the edge after extended use.
- ▶ Light strokes as you finish sharpening and honing will remove the burr quickly and produce the keenest edge.
- ▶ Creating a Micro-Bevel by increasing the sharpening angle by 2-3° can make re-honing your knife even faster.
- ▶ Edge Refinement Choices: For a durable 'toothy' edge, use the coarse diamond abrasive and lightly finish with the fine diamond. For a highly refined cutting edge, use all three abrasive grits and use light pressure as you finish each step before progressing to a finer grit.
- ▶ Stay clean when sharpening. Use a small brush or shop rag to keep knife and sharpener clean when progressing to finer grits.
- ▶ Sharpening Rod can be removed at any point in the process to optimize safety or ergonomics.
- ▶ Keep a Sharpening Log to document what edge angles you sharpen onto your knives.
- ▶ Dry Sharpening System – Do Not Use Oil or Water When Sharpening.
- ▶ Do not drag the Tri-Brasive® down onto or up onto the blade face or you risk scratching the surface.
- ▶ NEVER leave a knife mounted in the sharpener when not in use. Always store knives safely.
- ▶ Sharpening longer blades like kitchen knives may require you to remove V-Block Clamp™, flip over and reinstall into chassis. Clamping the blade closer to the end of the knife may allow you to use the 'flip over method' like smaller knives.
- ▶ Abrasives can be replaced individually, visit [WorkSharpTools.com](http://WorkSharpTools.com) to learn more.

PRECISION ADJUST  
KNIFE SHARPENER

## ELITE AND UPGRADE KIT

\*The Precision Adjust Elite and the Upgrade Kit contain additional components not included with the original Precision Adjust Knife Sharpener.

## SET UP

1. Tri-Brasive® and the Sharpening Rods
2. Sharpening Chassis snaps into the Sharpening Base
3. Insert Sharpening Rod Pin into Angle Selection Mechanism until magnet engages
4. V-Block Clamp™: Rotate knob to loosen jaws. Push V-Block Clamp™ firmly into the Sharpening Chassis to engage magnets.
5. Push the Spring-Loaded Button on the back of the Sharpening Chassis to rotate / index the V-Block Clamp™ 180°.

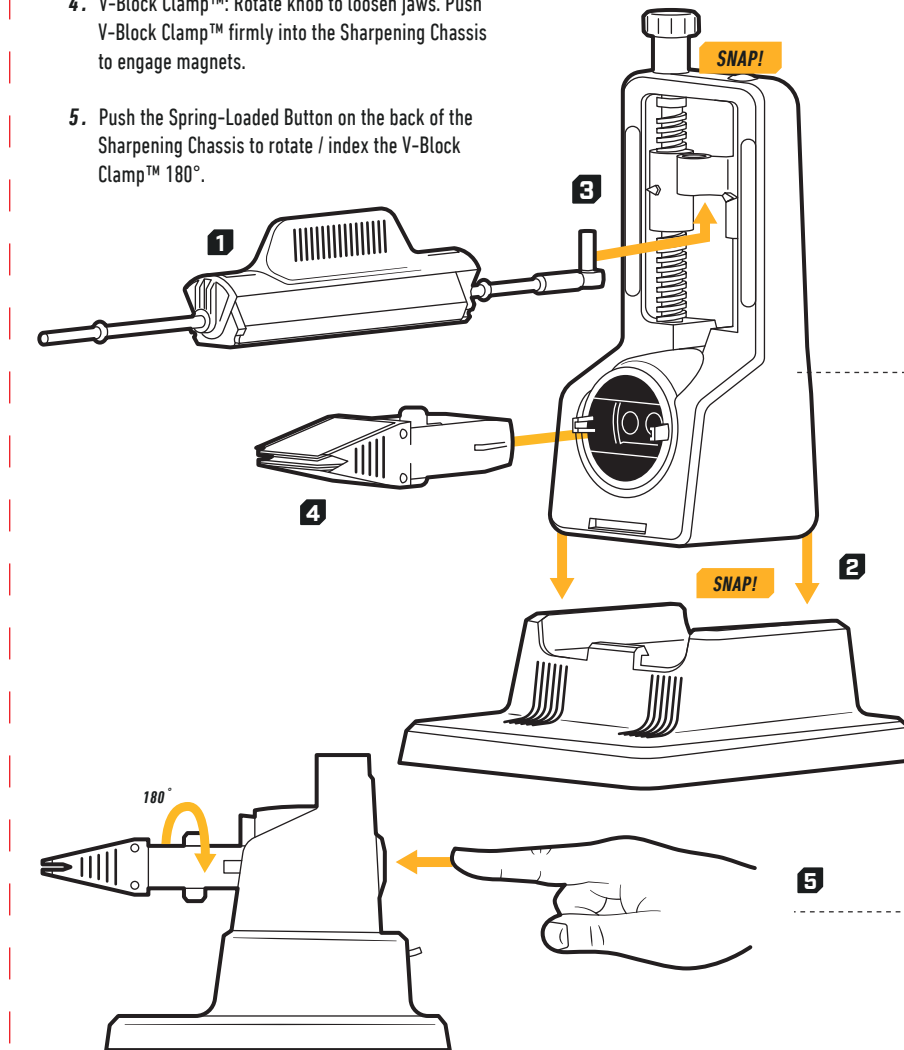

## CHOOSE YOUR ANGLE

## GENERAL

Low Edge Angles (15° to 22.5°):

Highest Sharpness, Lower Durability

High Edge Angles (23° to 30°):

Functional Sharpness, Higher Durability

## OUTDOOR KNIVES



Hunting Knife (light use / detail cutting): 20°

Hunting Knife (heavy use / hard cutting): 25°

Camp Knife (heavy use fixed blades): 30°

## KITCHEN



Western Style: 20°

Eastern Style: 15°

## POCKET KNIVES / EDC KNIVES



Heavy Use: 25°

Light Use: 20°

TURN THE ADJUSTMENT KNOB  
TO RAISE OR LOWER THE  
SHARPENING ANGLE

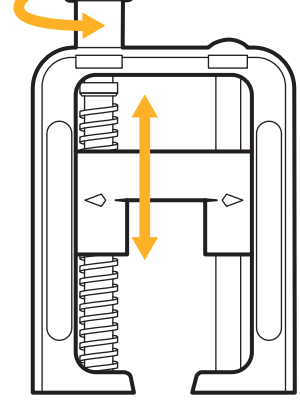

MACRO SCALE  
SETTING ON LEFT

MICRO SCALE  
(1° INCREMENTS)  
ON RIGHT

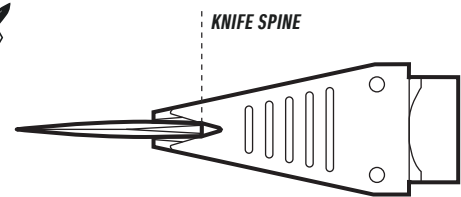

KNIFE SPINE

## CLAMPING YOUR KNIFE

Remove the V-Block Clamp™ from the Sharpening Chassis, loosen knob to open jaws.

Center the blade in the clamp jaws and place the knife spine into the V-Block. Align the cutting edge to be parallel with the clamp jaws. Squeeze the clamp jaws together to secure the blade position. Turn knob to secure knife blade in the clamp jaws.

Carefully insert the V-Block Clamp™ into the Sharpening Chassis – press firmly to secure onto magnets.

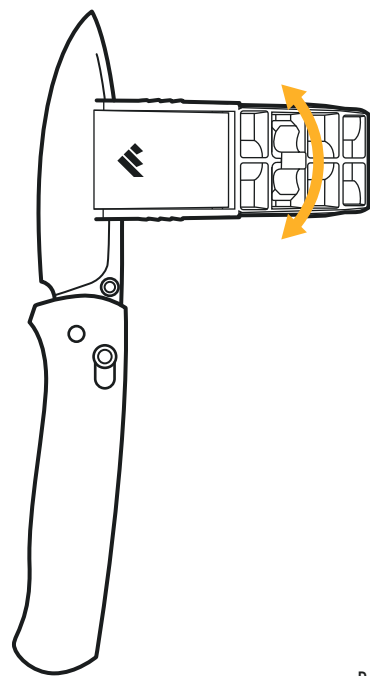

## CHOOSE YOUR GRIT

320 Coarse Grit Diamond Plate for Shaping.

600 Fine Grit Diamond Plate for Sharpening.

Fine Ceramic Stone for Honing.

## SHAPING

**WARNING:** Sharpening can be a dangerous task. Be aware of and in full control of your knife at all times or severe injury or death may occur.

Start the sharpening process using the coarse 320 grit diamond. Index the Tri-Brasive® so the 320 grit diamond is placed onto the cutting edge. (If you have the Elite System or Upgrade Kit, follow the grit progression outlined on page 5)

Using light pressure and long strokes, start at the heel of the blade and swipe the abrasive back and forth while moving along the length of the cutting edge toward the tip. STOP on the tip of the blade. **WARNING: Do not use excessive pressure when drawing the blade towards yourself. Use light pressure or you risk severe injury or death.**

Continue until you feel a burr along the entire length of the edge (on the opposite side you are sharpening). Keep an estimated stroke count so you can evenly sharpen the other bevel.

Once you have created a burr, press the spring loaded button on the back of the Sharpening Chassis and carefully rotate the V-Block Clamp™ 180° to sharpen the opposite side.

Sharpen the same number of strokes on this side of the blade to establish an even bevel.

Rotate the V-Block Clamp™ 180° again so the burr is now face up.

▶ **TIP:** You should be able to feel a very clear burr at this point. Do not proceed to the finer abrasives until you can feel or see the burr.

## SHARPENING

Rotate the Tri-Brasive® so the Fine 600 Grit Diamond is now face down onto the cutting edge.

Using the same technique in the SHAPING stage, sharpen blade for 8-10 strokes. Rotate the V-Block Clamp™ again to sharpen the other side of the blade and repeat 8-10 strokes.

▶ **TIP:** Light strokes and rotating the V-Block Clamp™ every other stroke as you finish this step will remove the burr quickly and produce the keenest edge.

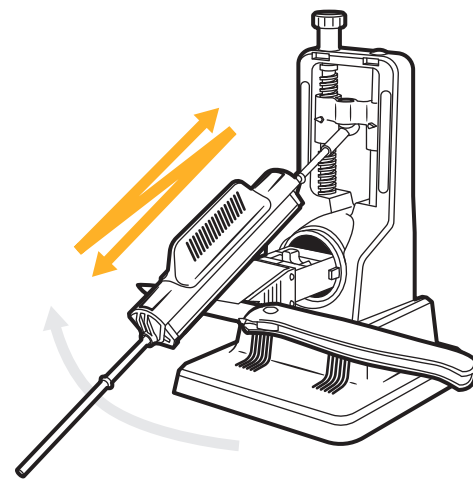

▶ **TIP:** Rubber O-Ring can be moved to adjust the amount of Tri-Brasive® 'slide' you desire when sharpening different knife types (EDCs versus kitchen knives).

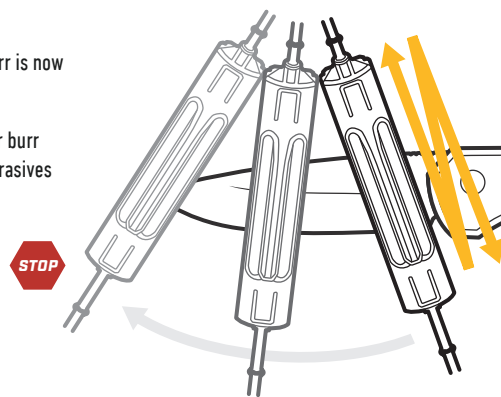

## HONING

Rotate the Tri-Brasive® so the Fine Ceramic is now face down onto the cutting edge.

Using the same technique in the SHARPENING stage, sharpen blade for 8-10 strokes. Rotate the V-Block Clamp™ again to sharpen the other side of the blade and repeat 8-10 strokes.

Check your edge for sharpness by ensuring the burr has been completely honed away.

Safely remove the V-Block Clamp™ from the Sharpening Chassis, then loosen the knob to remove the knife from the V-Block Clamp™.

## STROPPING AND SERRATIONS

\*These instructions are only applicable to the Precision Adjust Elite and the Upgrade Kit models.

## LEATHER STROP

After honing, install the Leather Strop and Rod.

Using light pressure and long strokes, start at the heel of the blade and swipe DOWNWARD 8-10 strokes on the leather, from top to bottom, always moving away from the cutting edge to avoid cutting leather.

Rotate to hone the other side of the blade, repeating same # of strokes.

Safely remove the knife.

## SERRATION SHARPENING

Hold the knife in your hands, with the serrations face up.

Remove the ceramic rod/leather assembly and place the ceramic rod into one of the serrations so it matches the angle.

Using light pressure, swipe the ceramic rod back-and-forth inside the Serration for 8-10 strokes. Repeat for each Serration.

Turn the knife over and lightly hone the back of the Serrations with the ceramic rod to remove any burr that may have been created.

▶ **TIP:** Strop & Hone can be removed from sharpening rod for improved ergonomics.

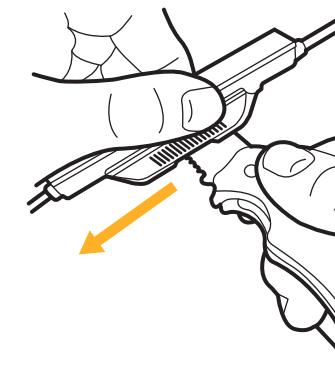
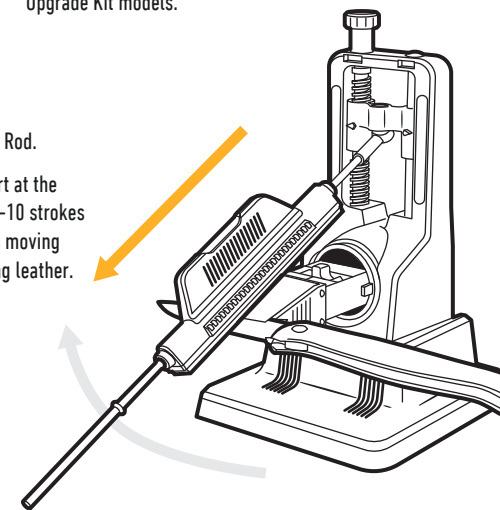

\*The below part configurations only come with the Precision Adjust Elite and the Upgrade Kit models.

## CHOOSE YOUR GRIT

220 Grit Diamond for Repair or Reprofitting

320 Grit Diamond for Shaping

400 Grit Diamond for Sharpening

600 Grit Diamond for Sharpening

800 Grit Diamond for Sharpening and further edge refinement

Fine Ceramic for Honing and further edge refinement

Ultra-Fine Leather Strop for Finishing and Polishing

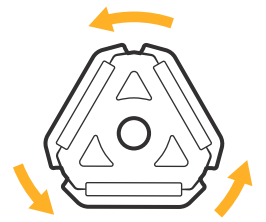

Rotate the Tri-Brasive® Rods  
to reveal other abrasives.

GRIT LEVEL	USE	EXTREMELY DULL EDGE REPAIR ANGLE CHANGE
220 GRIT	REPAIR	SHARPENING
320 GRIT	SHAPE	
400 GRIT	SHARPEN	TOUCH UPS
600 GRIT	SHARPEN	
800 GRIT	SHARPEN	
CERAMIC	HONE	
LEATHER	STROP	

Determine the condition of your knife and progress through each grit using the sharpening directions on page 3.

## COARSE TRI-BRASIVE®:

220 grit: ½" x 4"

320 grit: ½" x 4"

400 grit: ½" x 4"

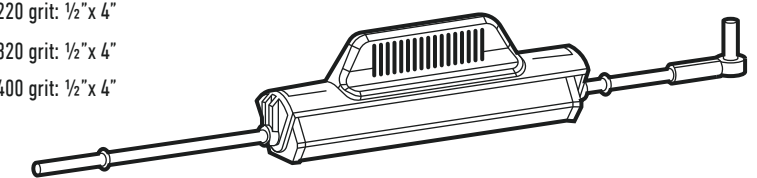

## FINE TRI-BRASIVE®:

600 grit: ½" x 4"

800 grit: ½" x 4"

Ceramic: ½" x 4"

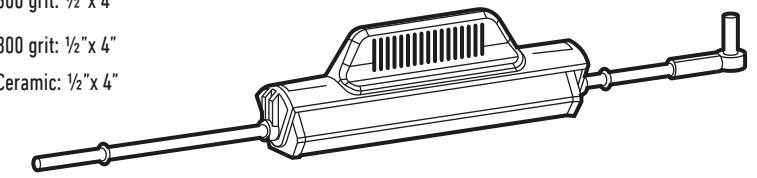

## LEATHER &amp; CERAMIC:

Ceramic Rod (for serrations): ⅛"

Leather Strop: ½" x 4"

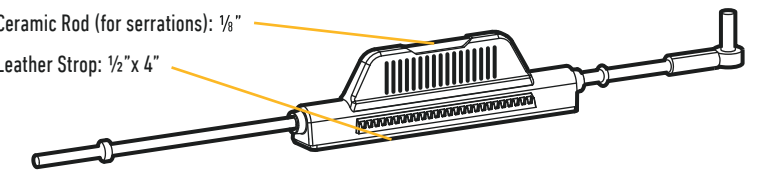

508mm

127mm

241mm

**SAFETY AND WARRANTY**

**SAFETY**

**WARNING:** This product contains magnets which may affect pacemakers. Failure to follow this warning could result in device malfunction.

**WARNING! CHOKING HAZARD!** Small parts, not for children under 3 years old.

**Notice:** Only use abrasives recommended for this tool in accordance with these instructions.

**WARNING!** To minimize the risk of injury, always use proper eye and respiratory protection. Failure to follow this warning could result in severe injury or death.

**WARRANTY**

**3 YEAR WARRANTY**

This sharpener is covered by Work Sharp's 3-year warranty. We stand behind and support our products – contact us if you need assistance, parts, or service.

Warranty for consumer not industrial or commercial use, excludes abrasives. Register your warranty online at WorkSharpTools.com.

Work Sharp® is a registered trademark of Darex, LLC  
For Patent Info Visit: worksharp.tools.com/patents  
Designed, calibrated and quality checked in Ashland, OR using foreign components.

**QUESTIONS?**

WorkSharpTools.com / 1.800.418.1439

**PLEASE LEAVE A REVIEW WHERE YOU PURCHASED YOUR PRODUCT**



**WORK SHARP**  
PO Box 730  
210 E. HERSEY ST.  
ASHLAND, OR 97520 USA



\*Excludes Abrasives

**TIPS AND TECHNIQUES**

- ▶ **CLAMPING A KNIFE:** Seat the blade spine into the V-Block Clamp™ with the blade centered in the Clamp Jaws. Align the cutting edge parallel to the clamp jaws if the knife design allows.

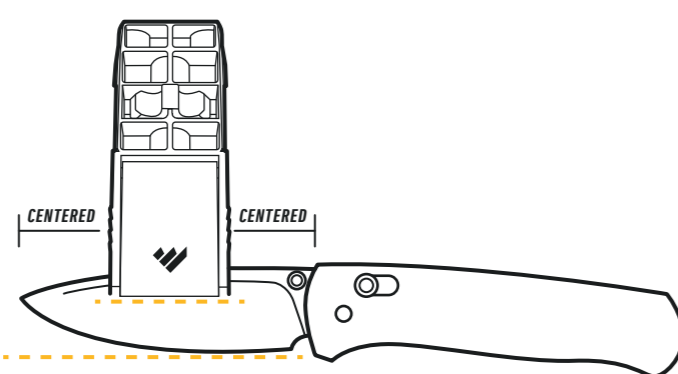

- ▶ **STARTING POSITION:** Note the white alignment mark on the sharpening chassis. Make sure it is pointing up. Insert the V-Block Clamp™ into the sharpening chassis so the knife handle is on the right side. This will make it easier to flip the blade over while sharpening smaller knives.

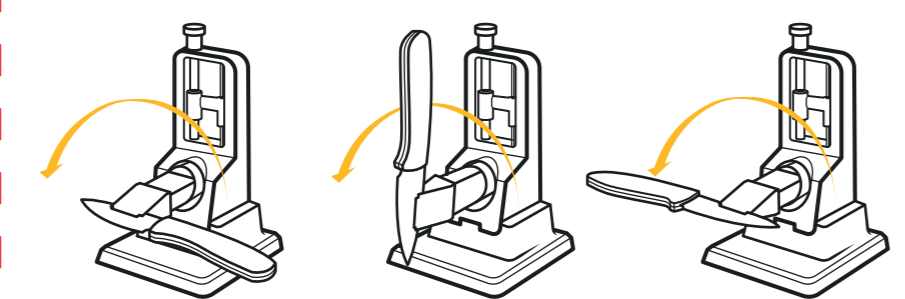
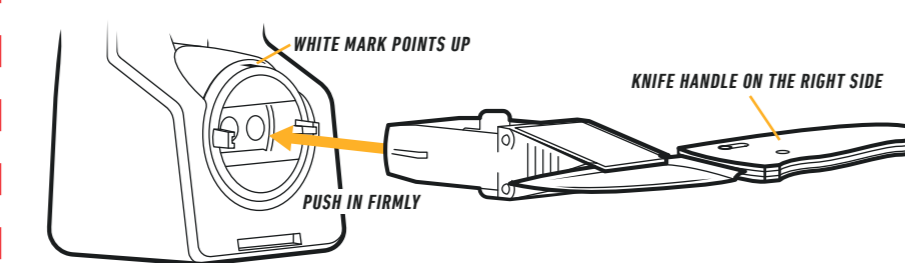

P.6

**TIPS AND TECHNIQUES**

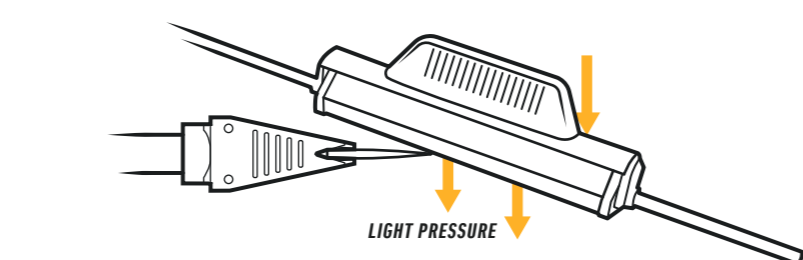

- ▶ Use light pressure when sharpening (weight of the Tri-Brasive™). Let the abrasive do the work and take your time. You'll get a better edge and you will have more fun doing it!

- ▶ First Time Sharpening: Use all three Tri-Brasive® grits to ensure you establish a consistent edge angle along the entire length of the blade and remove any edge damage or irregularities from previous sharpenings.

- ▶ Re-Sharpening: Use only the Ceramic Hone for frequent touch ups, the Fine Diamond may be required to restore the edge after extended use.

- ▶ Light strokes as you finish sharpening and honing will remove the burr quickly and produce the keenest edge.

- ▶ Creating a Micro-Bevel by increasing the sharpening angle by 2-3° can make re-honing your knife even faster.

- ▶ Edge Refinement Choices: For a durable 'toothy' edge, use the coarse diamond abrasive and lightly finish with the fine diamond. For a highly refined cutting edge, use all three abrasive grits and use light pressure as you finish each step before progressing to a finer grit.

- ▶ Stay clean when sharpening. Use a small brush or shop rag to keep knife and sharpener clean when progressing to finer grits.

- ▶ Sharpening Rod can be removed at any point in the process to optimize safety or ergonomics.

- ▶ Keep a Sharpening Log to document what edge angles you sharpen onto your knives.

- ▶ Dry Sharpening System – Do Not Use Oil or Water When Sharpening.

- ▶ Do not drag the Tri-Brasive® down onto or up onto the blade face or you risk scratching the surface.

- ▶ NEVER leave a knife mounted in the sharpener when not in use. Always store knives safely.

- ▶ Sharpening longer blades like kitchen knives may require you to remove V-Block Clamp™, flip over and reinstall into chassis. Clamping the blade closer to the end of the knife may allow you to use the 'tip over method' like smaller knives.

- ▶ Abrasives can be replaced individually, visit WorkSharpTools.com to learn more.

P.7

**INSTRUCTIONS**

**PRECISION ADJUST ELITE AND UPGRADE KIT**

\*The Precision Adjust Elite and the Upgrade Kit contain additional components not included with the original Precision Adjust Knife Sharpener.

**SET UP**

1. Tri-Brasive® and the Sharpening Rods
2. Sharpening Chassis snaps into the Sharpening Base
3. Insert Sharpening Rod Pin into Angle Selection Mechanism until magnet engages
4. V-Block Clamp™. Rotate knob to loosen jaws. Push V-Block Clamp™ firmly into the Sharpening Chassis to engage magnets.
5. Push the Spring-Loaded Button on the back of the Sharpening Chassis to rotate / index the V-Block Clamp™ 180°.

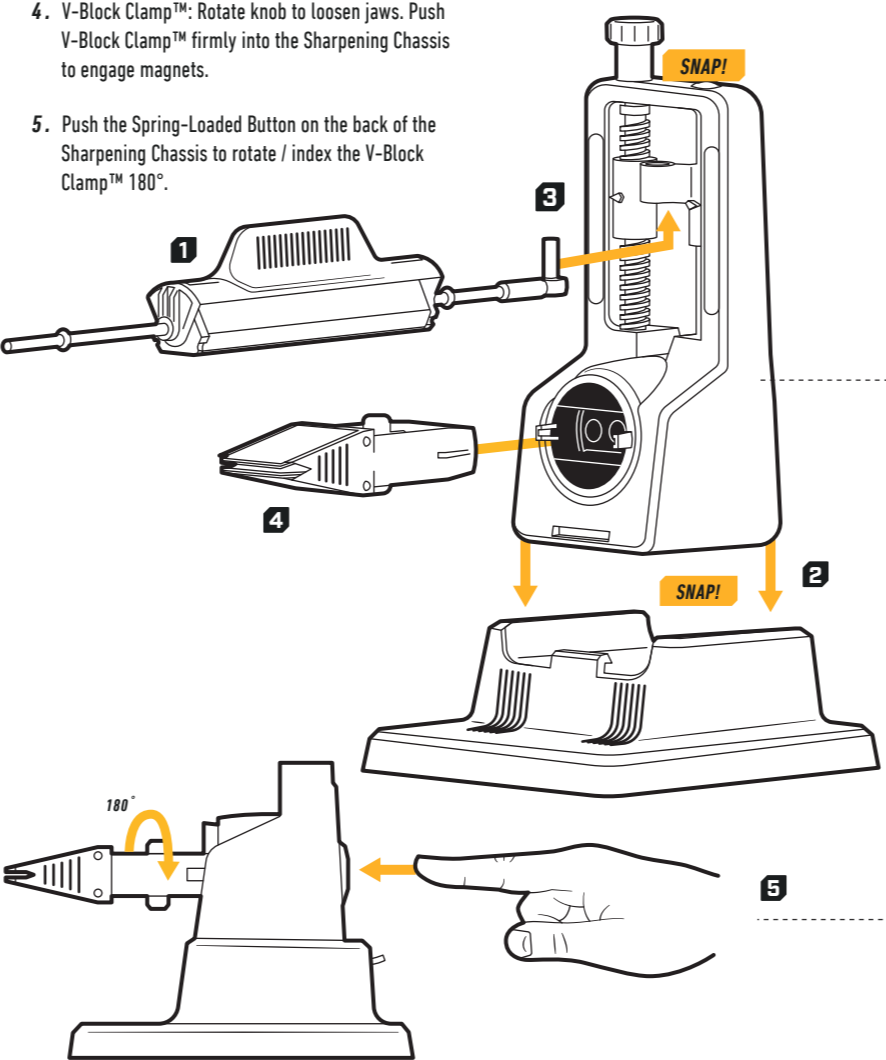

PP0004828 Rev 1 02/22

**STANDARD SHARPENING**

**CHOOSE YOUR ANGLE**

**GENERAL**

Low Edge Angles (15° to 22.5°): Highest Sharpness, Lower Durability

High Edge Angles (23° to 30°): Functional Sharpness, Higher Durability

**OUTDOOR KNIVES**

Hunting Knife (light use / detail cutting): 20°

Hunting Knife (heavy use / hard cutting): 25°

Camp Knife (heavy use fixed blades): 30°

**KITCHEN**

Western Style: 20°

Eastern Style: 15°

**POCKET KNIVES / EDC KNIVES**

Heavy Use: 25°

Light Use: 20°

**CLAMPING YOUR KNIFE**

Remove the V-Block Clamp™ from the Sharpening Chassis, loosen knob to open jaws.

Center the blade in the clamp jaws and place the knife spine into the V-Block. Align the cutting edge to be parallel with the clamp jaws. Squeeze the clamp jaws together to secure the blade position. Turn knob to secure knife blade in the clamp jaws.

Carefully insert the V-Block Clamp™ into the Sharpening Chassis – press firmly to secure onto magnets.

**CHOOSE YOUR GRIT**

320 Coarse Grit Diamond Plate for Shaping.

600 Fine Grit Diamond Plate for Sharpening.

Fine Ceramic Stone for Honing.

**SHARPENING**

**GENERAL**

Low Edge Angles (15° to 22.5°): Highest Sharpness, Lower Durability

High Edge Angles (23° to 30°): Functional Sharpness, Higher Durability

**OUTDOOR KNIVES**

Hunting Knife (light use / detail cutting): 20°

Hunting Knife (heavy use / hard cutting): 25°

Camp Knife (heavy use fixed blades): 30°

**KITCHEN**

Western Style: 20°

Eastern Style: 15°

**POCKET KNIVES / EDC KNIVES**

Heavy Use: 25°

Light Use: 20°

**CLAMPING YOUR KNIFE**

Remove the V-Block Clamp™ from the Sharpening Chassis, loosen knob to open jaws.

Center the blade in the clamp jaws and place the knife spine into the V-Block. Align the cutting edge to be parallel with the clamp jaws. Squeeze the clamp jaws together to secure the blade position. Turn knob to secure knife blade in the clamp jaws.

Carefully insert the V-Block Clamp™ into the Sharpening Chassis – press firmly to secure onto magnets.

**CHOOSE YOUR GRIT**

320 Coarse Grit Diamond Plate for Shaping.

600 Fine Grit Diamond Plate for Sharpening.

Fine Ceramic Stone for Honing.

**SHARPENING**

**SHAPING**

**WARNING:** Sharpening can be a dangerous task. Be aware of and in full control of your knife at all times or severe injury or death may occur.

Start the sharpening process using the coarse 320 grit diamond plate on the Tri-Brasive® up the 320 grit diamond is placed onto the cutting edge. (If you have the Elite System or Upgrade Kit, follow the grit progression outlined on page 5)

Using light pressure and long strokes, start at the heel of the blade and swipe the abrasive back and forth while moving along the length of the cutting edge toward the tip. STOP on the tip of the blade. **WARNING: Do not use excessive pressure when drawing the blade towards yourself. Use light pressure or you risk severe injury or death.**

Continue until you feel a burr along the entire length of the edge (on the opposite side you are sharpening). Keep an estimated stroke count so you can evenly sharpen the other bevel.

Once you have created a burr, press the spring loaded button on the back of the Sharpening Chassis and carefully rotate the V-Block Clamp™ 180° to sharpen the opposite side.

Sharpen the same number of strokes on this side of the blade to establish an even bevel.

Rotate the V-Block Clamp™ 180° again so the burr is now face up.

▶ **TIP:** You should be able to feel a very clear burr at this point. Do not proceed to the finer abrasives until you can feel or see the burr.

**SHARPENING**

Rotate the Tri-Brasive® so the Fine 600 Grit Diamond is now face down onto the cutting edge.

Using the same technique in the SHAPING stage, sharpen blade for 8-10 strokes. Rotate the V-Block Clamp™ again to sharpen the other side of the blade and repeat 8-10 strokes.

▶ **TIP:** Light strokes and rotating the V-Block Clamp™ every other stroke as you finish this step will remove the burr quickly and produce the keenest edge.

**SHARPENING**

**HONING**

Rotate the Tri-Brasive® so the Fine Ceramic is now face down onto the cutting edge.

Using the same technique in the SHARPENING stage, sharpen blade for 8-10 strokes. Rotate the V-Block Clamp™ again to sharpen the other side of the blade and repeat 8-10 strokes.

Check your edge for sharpness by ensuring the burr has been completely honed away.

Safely remove the V-Block Clamp™ from the Sharpening Chassis, then loosen the knob to remove the knife from the V-Block Clamp™.

**STROPPING AND SERRATIONS**

\*These instructions are only applicable to the Precision Adjust Elite and the Upgrade Kit models.

**LEATHER STROP**

After honing, install the Leather Strop and Rod.

Using light pressure and long strokes, start at the heel of the blade and swipe DOWNWARD 8-10 strokes on the leather, from top to bottom, always moving away from the cutting edge to avoid cutting leather.

Rotate to hone the other side of the blade, repeating same # of strokes.

Safely remove the knife.

**SERRATION SHARPENING**

Hold the knife in your hands, with the serrations face up.

Remove the ceramic rod/leather assembly and place the ceramic rod into one of the serrations so it matches the angle.

Using light pressure, swipe the ceramic rod back-and-forth inside the Serration for 8-10 strokes. Repeat for each Serration.

Turn the knife over and lightly hone the back of the Serrations with the ceramic rod to remove any burr that may have been created.

▶ **TIP:** Strop & Hone can be removed from sharpening rod for improved ergonomics.

P.3

**ELITE/UPGRADE KIT GRITS**

\*The below part configurations only come with the Precision Adjust Elite and the Upgrade Kit models.

**CHOOSE YOUR GRIT**

- 220 Grit Diamond for Repair or Reprofitting
- 320 Grit Diamond for Shaping
- 400 Grit Diamond for Sharpening
- 600 Grit Diamond for Sharpening
- 800 Grit Diamond for Sharpening and further edge refinement
- Fine Ceramic for Honing and further edge refinement
- Ultra-Fine Leather Strop for Finishing and Polishing

GRIT LEVEL	USE	EXTREMELY DULL EDGE REPAIR	ANGLE CHANGE
220 GRIT	REPAIR	SHARPENING	TIPDOWN OPS
320 GRIT	SHAPE		
400 GRIT	SHARPEN	SHARPENING	TIPDOWN OPS
600 GRIT	SHARPEN		
800 GRIT	SHARPEN	SHARPENING	TIPDOWN OPS
CERAMIC	HONE		
LEATHER	STROP	SHARPENING	TIPDOWN OPS

Determine the condition of your knife and progress through each grit using the sharpening directions on page 3.

**COARSE TRI-BRASIVE®:**

220 grit: 1/2" x 4"

320 grit: 1/2" x 4"

400 grit: 1/2" x 4"

**FINE TRI-BRASIVE®:**

600 grit: 1/2" x 4"

800 grit: 1/2" x 4"

Ceramic: 1/2" x 4"

**LEATHER & CERAMIC:**

Ceramic Rod (for serrations): 1/2"

Leather Strop: 1/2" x 4"

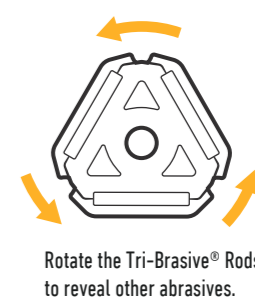

P.4

P.5

<b>NOTES:</b>	<b>SPOT COLOR:</b>	<b>WORK SHARP</b>
<b>CUT:</b> _____	N/A	210 E. HERSEY ST.
<b>CREASE/FOLD:</b> - - - - -		ASHLAND, OR 97520
<b>BLEED LINE:</b> _____		PHONE: (+1) 541-552-1301
		FAX: 541-552-1377
<b>TITLE:</b> Precision Adjust, ELT, UK Users Guide		
<b>MATERIAL:</b>	157 GSM Coated Art Paper	<b>PART#:</b> PP0004828
<b>COATING:</b>	Standard Coating	<b>REV:</b> 1
<b>FLUTE DIRECTION:</b>	N/A	<b>DATE:</b> 02/15/2022
<b>FOLD INSTRUCTIONS:</b> Accordion Fold such that *Instructions* page is on the front.		
<b>REV NOTES:</b> Dimensions added and Key adjusted per CR 2507.		